

Parallel Implementation on DSPs of a Face Detection Algorithm

F. YANG, M. PAINDAVOINE, H. ABDI

Laboratoire LE2I

Université de Bourgogne

BP400 - 21000 Dijon, France

Tél : (33).03.80.39.63.33 , Fax : (33).03.80.39.60.47

E-mail : fanyang@satie.u-bourgogne.fr

Abstract

In order to localize the face in an image, our approach consists to approximate the face oval shape with an ellipse and to compute coordinates of the center of the ellipse. For this purpose, we explore a new version of the Hough transformation : the Fuzzy Generalized Hough transformation. To reduce the computation time, we present also a parallel implementation of the algorithm on 2 Digital Signal Processors and we show that an acceleration of factor 1.62 has been obtained.

1 Introduction

The Hough transformation is a procedure for curves detection, which can be specified with a small number of parameters (straight lines, circles, parabola, ...). Our intention is to determine, with the method based on the Hough transformation the location of human faces in an image. In general, the shape of a human face can't be described easily with an analytical curve, but can be approximated with an ellipse. If we compute coordinates of the center of the ellipse and the length of its diameters, we can determine borders of the face. This process corresponds to the first step of face identification and face categorization.

For this purpose, a new version of the Hough transformation is used : the Fuzzy Generalized Hough Transformation (FGHT)[1] [2] which allows a fast face contour detection in an image. Considering the necessary computation amounts, we also present parallel implementations of this face detection algorithm on Digital Signal Processors (DSP) using SYNDEX (SYnchronous Distributed Executive) which is a programming environment to generate, optimize and distribute real-time executives[5] [6].

In this paper, first the human face detection algorithm is described in the second section. Then, parallel implementations have been realized on several processors (DSP TMS320C40). We show in the third section that an optimized mapping between the algorithm and the architecture has been obtained with the SYNDEX tool.

2 Algorithm Description

For human face detection in an image, our approach consists to approximate the face oval shape with an ellipse and to compute coordinates of the center of the ellipse.

Edges detection and Edges thinning : The Shen and Castan filter[3] is used for edges detection in an image. First, we obtain the edges gradient using a convolution between the original image and the filter :

$$\begin{aligned} S_{Ld} &= (1-b)x(i) + bS_{Ld}(i-1) \quad i = 1 \dots N \\ S_{Rd} &= (1-b)x(i) + bS_{Rd}(i+1) \quad i = N \dots 1 \end{aligned} \quad (1)$$

$$\begin{aligned} D_1(i) &= S_{Rd}(i+1) - S_{Ld}(i-1) \\ D_2(i) &= S_{Rd}(i+1) + S_{Ld}(i-1) - 2 * x(i) \end{aligned}$$

with: $x(i)$: gray-level pixel i , b : coefficient, $D_1(i)$, $D_2(i)$: first and second derivatives. Then, a test using the sign of first and second derivatives of image has been realized to thin the edges.

Hough transformation for an ellipse based on an edge gradient : Each ellipse in an image space can be presented with a single point in parameter space. We exploit sign and value of edge gradient to reduce drastically the computation and the necessary memory. We present the center of an ellipse which goes through edge point (x, y) in the mathematical form using[1] :



Fig.1 - Results of face location in an image : original images and faces location detected with our method.

$$\begin{aligned}
 x_c &= x + \text{sign}(dLx) \frac{lh}{\sqrt{1 + \left(\frac{lv}{lh}\right)^2 \left(\frac{dLy}{dLx}\right)^2}} \\
 y_c &= y + \text{sign}(dLy) \frac{lh}{\sqrt{1 + \left(\frac{lh}{lv}\right)^2 \left(\frac{dLx}{dLy}\right)^2}}
 \end{aligned} \quad (2)$$

Where x_c and y_c determine two coordinates of the center of an ellipse, and lh , lv determine two axes. dLx , dLy have been obtained from the edge pixel information. The ratio $\frac{lh}{lv}$ changes between 1.2 and 1.7 for human face[2], and we choose here an ideal ratio $\frac{lh}{lv} = 1.5$ with $lv = 32$ as constants to simplify the computation.

Face contour approximation with an ellipse curve doesn't define a perfect ellipse. A new version of Hough Transformation : Fuzzy Generalized Hough Transformation (FGHT) has been used to improve the precision of the system for our application.

Detection of the position of human faces : Location of human faces in an image corresponds first to search the maximum value in parameter space (accumulator). Then, this maximum value is replaced with zeros to search other potential human faces. The figure 1 shows the results of face location in an image.

This algorithm FGHT is a "low-level" processing, and the time of computation improves quickly when the size of image increases. To solve the computation time, we present parallel implementations of the algorithm in the next section.

3 Parallel implementations on multi-DSPs

The applied architecture for parallel implementation is a TDMB408 Board from Transtech which contains 3 Texas Instrument TMS320C40 on line and a CFG40 Module (Frame-Grabber). The parallel implementations have been realized using SYnDEx which is an interactive graphical software environment for signal processing and process control real-time application running on multiprocessors[5]. It offers the following functionalities : interface with the synchronous language SIGNAL, specification and sizing of the multiprocessor, semi-automatic partitioning and scheduling optimization, automatic executive generation. We present two parallel implementations :

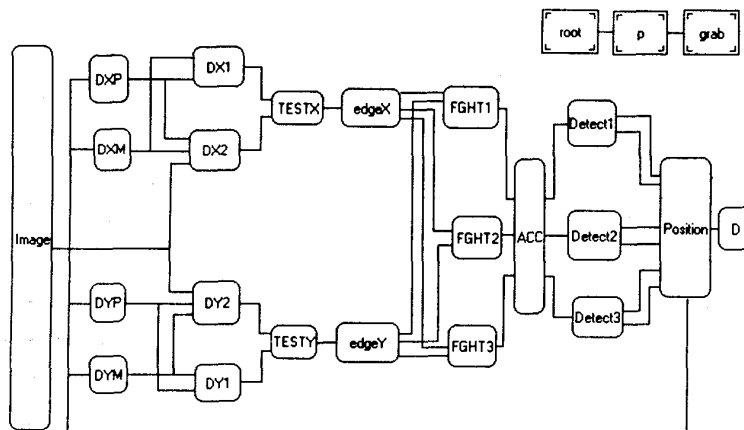

Fig.2 - SYnDEx graph Browser.

First parallel implementation :

The parallel implementation has been realized in data-flow mode. The figure 2 shows the SYnDEX graph Browser which represents the data-flow graph and the corresponding architecture (root, p, grab)[6].

For an image (a data-flow) :

- 1). computes DXP, DXM, DYP, DYM (S_{Ld} et S_{Rd} from the equation (1)) for directions X and Y,
- 2). computes first and second derivatives DX1, DY1, DX2, DY2,
- 3). tests signs of DX1, DY1, DX2, DY2 to thin the edges,

- 4). divides image edge into 3 blocks and realizes the FGHT for each block,
- 5). divides parameter space into 3 blocks and searches local maximum value,
- 6). localizes human face using global maximum value.

The figure 3 displays the partitioning and the scheduling of this parallel implementation. We have only an effectiveness of 0.45 (acceleration=1.35). For this parallel implementation on the 3 DSPs, we have much time of inter-DSPs communication (the time of communication is comparable with the time of computation).

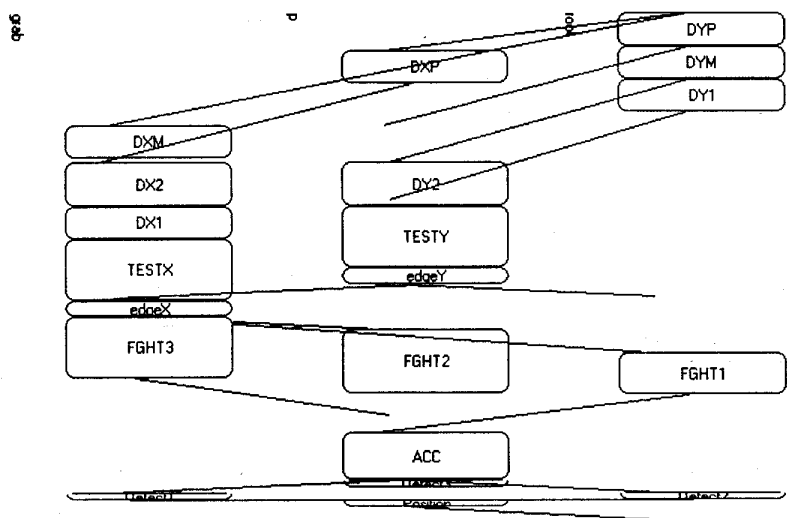

Fig.3 - SYnDEX graph temporal diagram.

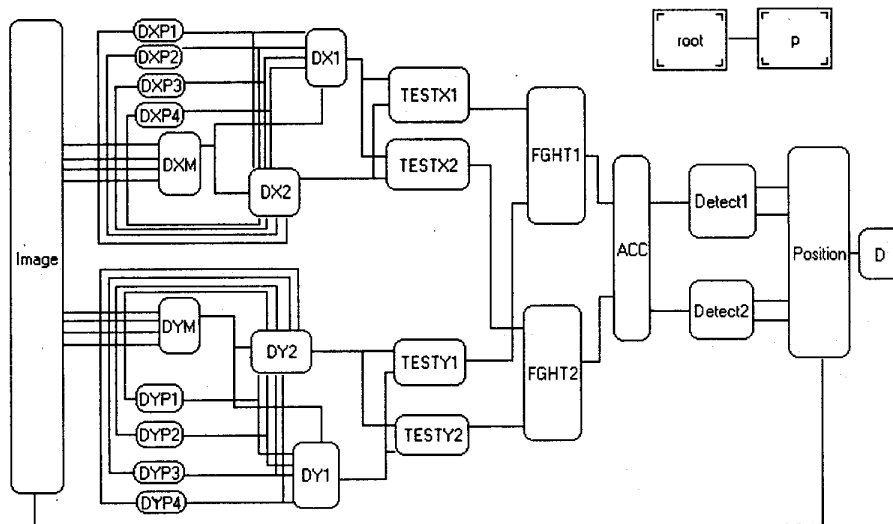

Fig.4 - SYnDEX graph Browser.

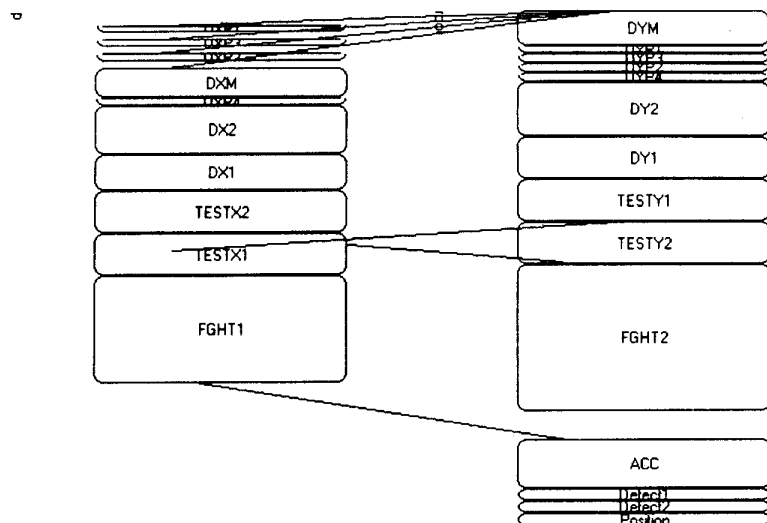

Fig.5 - SYnDEx graph temporal diagram.

Table 1: Execution timing (μs)

T_{DXP}	T_{DX1}	T_{DX2}	T_{TEST}	T_{FGHT}	T_{ACC}	$T_{Detect1}$	T_{seq}	T_{para}	$E = \frac{T_{seq}}{N_{pr}T_{para}}$
21960	21783	30606	26253	66877	30011	7368	509725	314645	0.81

Second parallel implementation :

The SYnDEx graph Browser is displayed in the figure 4. This parallel implementation has been only realized using 2 DSPs. We have reduced the grain of data-parallelism in the part of edges and edges thinning to accelerate the inter-DSPs communication time. The execution timing (see Fig.5 and Tab.1) shows that we have obtained an effectiveness of factor 0.81 (acceleration=1.62).

4 Conclusion

In this paper, we have presented a method based on the Hough Transformation for face contour detection. The parallel implementations of this algorithm have been realized on 3 and 2 DSPs TMS320C40. Using the second implementation we can process 3.2 images of size 143×123 per second. We have used SYnDEx environment and this simplified the development of the parallel implementation. With this experience, we hope to implement other images processing algorithms like face recognition.

References

- [1] J.Korosec, L.Gyergyek and al, *Face contour detection based on the Hough transformation*, Automatika, Vol.31, 1990.
- [2] R.Seguirer, *Détection et localisation de visages dans des séquences d'images vidéo*, Thèse soutenue à l'Université de Rennes I, 1995.
- [3] J.Shen, S.Castan, *An optimal linear operator for step edge detection*, Graphical Models and Image processing, Vol.54, 1991.
- [4] J.Han, L.T.Koczy and T.Poston, *Fuzzy Hough Transform*, Pattern Recognition Letters, Vol.15, 1994.
- [5] Y.Sorel and C.Lavarenne, *SYnDEx v4.2 INRIA: CAD for the optimized implementation of real-time algorithms on multicomponent architecture*, Technical Report, INRIA, 1996.
- [6] C.Lavarenne and Y.Sorel, *Performance optimization of Multiprocessor Real-time Applications by Graph Transformations*, Parallel Computing, Grenoble, 1993.