

Lab 2: Rectifiers

Objectives

The objective of this lab is for you to become familiar with the functionality of a diode in circuits. We will experiment the use of diodes in limiting and rectifying circuits. We will also learn how to use LabView – a virtual instrument and automated measurement program.

Introduction

The circuits we will be working with are the basic limiting circuit, half-wave and full-wave rectifiers. We will analyze these diode circuits using 1) approximation, e.g., assuming that we know the voltage drop V_f across the diode; 2) graphical method to find the voltage and current of the diode; 3) bias analysis with PSpice which is equivalent to solving the circuit with an iterative method. Lastly, we will measure in lab the actual voltage and current values in these circuits to evaluate the accuracy of these various analysis methods for diode circuits.

In addition, we will characterize the transfer function of some diode circuits, and use it to predict the circuit output waveform for a given input. We will crosscheck our measurement results with those obtained from PSpice simulation.

(Note: for a complete tutorial of diode theory and analysis methods, please refer to your EE/CE 3311 lecture notes or an equivalent textbook for the topic **limiting and rectifying circuits**.)

Preparation

For the first two circuits, the limiter and the half-wave rectifier, we will perform the analysis using multiple methods.

Limiting Circuit

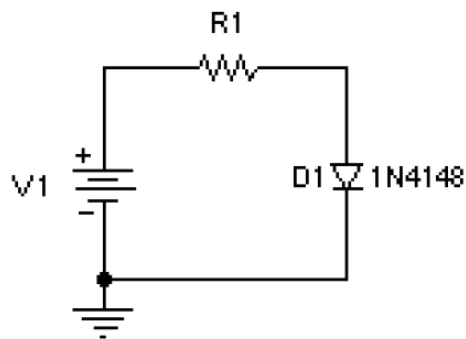

Figure 2-1: Basic limiting circuit

1. Approximation: For the circuit shown in Fig. 2-1 with $V_1 = 5V$, using the assumption $V_f = 0.7V$, find the resistor value you need to set the diode current to 5mA. This gives you the first set of operating-point data for the diode [0.7V, 5mA]. The resistor value will be used for the following steps.
2. Iterative solution: Enter the circuit schematics into PSpice, run a bias analysis and find out the value of the current and voltage of the diode. Second set of data.
3. Graphical solution: Use a DC sweep in PSpice to plot the I-V characteristic of the diode, plot on the same graph the load line of R1 and find the voltage and current of the diode. Third set of data.
4. Use a DC sweep in PSpice to plot the transfer function (diode voltage divided by V1) of the circuit. Use the plot to estimate and sketch the output (diode voltage) waveform when the input (V1) is replaced by a $\pm 5V$, 1kHz triangular wave.
5. Use PSpice to run a transient simulation for the circuit in step 4. Plot the output waveform and compare it with your results in step 4.
6. Add a sinusoidal source (Vsin) to your schematic in series with V1 with an amplitude of 1mV and a frequency of 1KHz. Run a transient simulation. Repeat the simulation for an amplitude of 6V. Plot both outputs. Do a hand calculation using the transfer function you obtained in step 4, compare your result with the simulation.

Half-Wave Rectifier

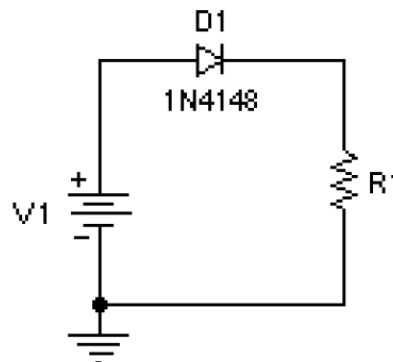

Figure 2-2: Half-wave rectifier

1. Approximation: Using the assumption $V_f = 0.7V$, analyze the circuit in Fig. 2-2 for $V_1 = 5V$ and $R_1 = 3.3k$. First set of data.
2. Iterative solution: Use PSpice to find the diode current and voltage for the same V_1 and R_1 as in step 1. Second set of data.
3. Graphical solution: Now your load is the diode. Use PSpice to plot the resistor's I-V characteristic, then plot the load line and find the voltage and current of the diode. Third set of data.
4. Use PSpice to plot the transfer function (resistor voltage divided by V1) of the circuit. Use it to sketch the output (resistor voltage) waveform when the input (V1) is replaced by a $\pm 5V$, 1kHz triangular wave.
5. Use PSpice to run a transient simulation for the circuit in step 4. Plot the output waveform and compare it with your results in step 4.

Full-Wave Rectifier

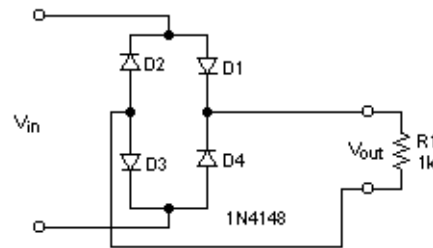

Figure 2-3: Full-wave rectifier

1. Use PSpice to obtain a plot of the transfer function of the circuit shown in Fig. 2-3. Use the plot to estimate the output if the input is a sine wave with 10V amplitude and 60Hz of frequency.
2. Use PSpice to plot the output of the rectifier circuit driven by the sinusoidal input source in step 1.

Ripple Voltage: Ripple voltage is a parameter associated with rectifier circuits with bypass capacitors, e.g., C1 in the circuit shown in Fig. 2-4. Such circuits are better known as **power supplies**. The ripple voltage is defined as the peak-to-peak (pp) voltage of the waveform seen at the output node of a power supply when an external load is connected – the impedance of the load will influence the magnitude of the ripple voltage. Typically, the ripple voltage is inversely proportional to the load impedance.

In general, the ripple voltage is seen by the load as noise. In order to minimize that noise we can add an additional circuit, the **voltage regulator**, to the rectifier. The simplest regulator is the combination of a resistor and a zener diode. Using the voltage regulator we can assure the delivery of a better DC voltage to the load. The circuit in Fig. 2-4 shows the configuration that combines a rectifier with a bypass capacitor (C1) to make a power supply, and then the power supply with a voltage regulator (R1 and zener) to finally obtain a circuit called **voltage-regulated power supply**.

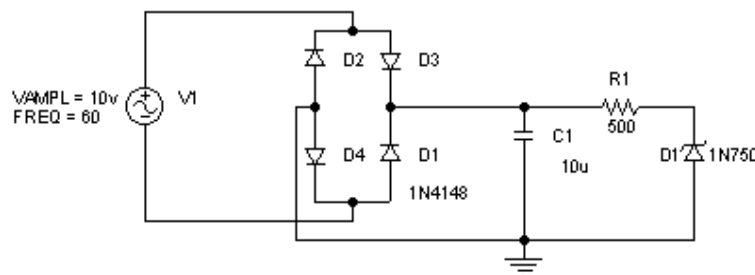

Figure 2-4: Voltage-regulated power supply

Use PSpice to determine the minimum resistor value you can use as a load of the voltage-regulated power supply in parallel to the zener diode such that the output **DC voltage**, i.e., the average value of the output voltage over time, does not decay more than 10% of its value without the load. Note that the output is to be taken across the zener diode.

Procedure

Perform the following experiments and measurements during your lab session.

1. Use the LabView program *iv_curve.vi* to obtain the I-V characteristic of the diode you will be using.
Warning: to avoid burning the diode make sure you limit the current supplied to it by setting a safe current limit on your power supply – ask your TA if you don't know how to do this.
2. Build the circuit shown in Fig. 2-1 with the component values used in the preparation section; use a voltmeter and an ammeter to measure the current and voltage of the diode.
3. Build the circuit shown in Fig. 2-2 with the component values used in the preparation section; measure the current and voltage of the diode. Also record the output waveform of this circuit when the DC source is replaced by a sine wave with the same parameters used for the full-wave rectifier in the preparation section.
4. Build the full-wave rectifier shown in Fig. 2-3 with the component values used in the preparation section; use the LabView program *tranchar.vi* to obtain the transfer function of the circuit. Then apply a sine wave identical to that used in the preparation section, and record the output waveform.
5. Using the same circuit of step 4, add a capacitor in parallel to the 1k resistor. Measure the peak-to-peak voltage (ripple voltage) at the output and record the output waveform. Repeat this step for $C = 100\mu, 10\mu, 1\mu$, and no capacitor.
6. Build the circuit shown in Fig. 2-4 and measure the DC (average) and AC (rms and pp) voltages at the zener terminals. Attach a resistor box in parallel to the zener, start with a big value 220k, and then reduce the resistance until you see an output **DC voltage** of 90% of its value without the load. Record the value of the resistor.

Analysis

1. Use the diode I-V characteristic you measured in lab and the graphical method to find the voltage and current of the diode for the limiter and the half wave rectifier. Compare these values with the values you obtained in preparation with different analysis methods and those obtained from lab measurement in steps 2 and 3. Tabulate all these results for clear comparison.
2. Use PSpice to determine the ripple voltage for different values of the bypass capacitor in step 5. Sweep the capacitance from 1μ to 100μ with at least ten data points, plot the ripple voltage versus the capacitance. Mark the data points you measured in lab on the same plot. Do the measured values agree well with the plot obtained using PSpice?

Thoughtful Questions

In the full-wave rectifier circuit shown in Fig. 2-3, determine what will happen to the circuit if 1) D1 is disconnected, 2) D1's polarity is reversed, with everything else being the same. Sketch the waveforms across the 1k load resistor first and then do a PSpice simulation to verify your results. Will the problems cause a hazardous situation? If so, which one or both?

(FYI, these conditions represent what can really happen in a lab... don't make that happen in your experiments!)

Lab 2 Report Instructions

General rules about lab report (applicable to all following lab reports of this semester):

1. Please use a word processor to typeset your report.
2. Please write the following info on the front page of your report:
 - Course number & name
 - Section number
 - Experiment number & name
 - TA name
 - Your name and student ID
3. Your report should include at least the following sections:
 - Objectives
 - Simulation results (if any)
 - Experimental results (if any)
 - Analysis (if any)
 - Thoughtful Questions (if any)
 - Conclusion
4. Answer the questions listed in the Thoughtful Questions section in the lab manual.

Besides the general rules above, specific guidelines for this lab:

1. The lab report should be segmented in to the following parts:
 - Limiting circuit
 - Half-wave rectifier
 - Full-wave rectifier
 - Ripple voltage circuit (voltage-regulated power supply circuit)
2. In each part above, you should report results from both the preparation and procedure sections. Do the exercise in the analysis section.
3. Compare results obtained for the same circuit from preparation, procedure, and analysis sections. Tabulate these comparisons. What's your observation about the pros and cons of these different techniques?
4. Answer the thoughtful questions.